

Acme Pumps

Type MVD multistage
Vertical centrifugal pumps

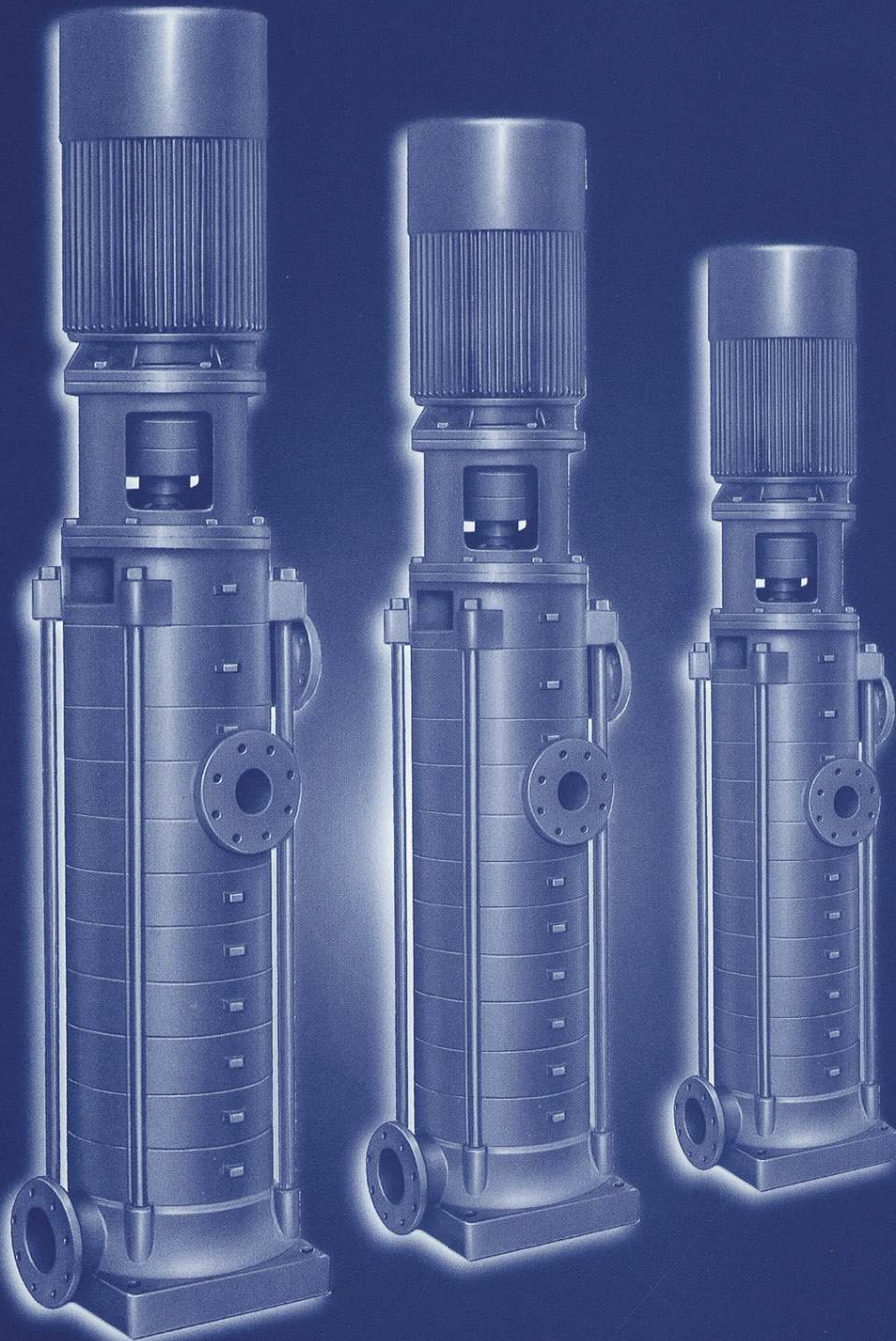

40 bar working pressure · multiple outlet design · available in cast iron · ductile iron · cast steel · stainless steel

Description

ACME MVD MULTISTAGE VERTICAL DONUT PUMPS are designed for water transfer, fire protection, pressure boosting, boiler feed and other applications where noise and vibration must be kept to a minimum.

It is a low flow, high-pressure pump that offers users high efficiency, reliability at low cost. It also requires less installation space and provides piping flexibility and ease of maintenance.

Features

Casing	Robust design provides solid foundation for trouble free operation. Available in Cast Iron, Ductile Iron, Cast Steel or Stainless Steel with minimum casing working pressure of 40 kg/cm ² (580 PSIG).
Impeller	Precision casting stainless steel impeller is standard on all ACME MVD pumps. They are keyed to shaft for positive drive and offer high efficiency.
Diffuser	MVD pumps are provided with diffusers to ensure that radial load is minimized when the pumps are operated at reduced flow.
Balancing Drum	Hydraulic balancing is achieved by balancing drum. This reduces the axial load on the bearing to a minimum and increases the bearing life.
Bearings	<p>MVD pumps are fitted with angular contact grease lubricated ball bearing as standard. Oil lubricated bearings are available as an option.</p> <p>The radial bearings are available in coke filled TFE, Silicon Carbide or Tungstun Carbide. They offer the highest mean time between pump maintenance and reduce operation cost.</p> <p>The radial bearing is mounted on a removable housing for ease of maintenance without removing other parts of the pump.</p>
Shaft and Shaft Sleeve	Available in high tensile steel, 416 Stainless Steel or Duplex Stainless Steel with replaceable sleeve to minimize maintenance cost.
Stuffing Box	The stuffing box can be provided with packing or mechanical seals. When mechanical seals are used, they can be replaced without dismantling the pump.
Multiple Outlet	MVD pumps can be fitted with multiple outlets that enable users to tap different discharge pressure to meet the system requirement with single pump installation.

Construction & Materials

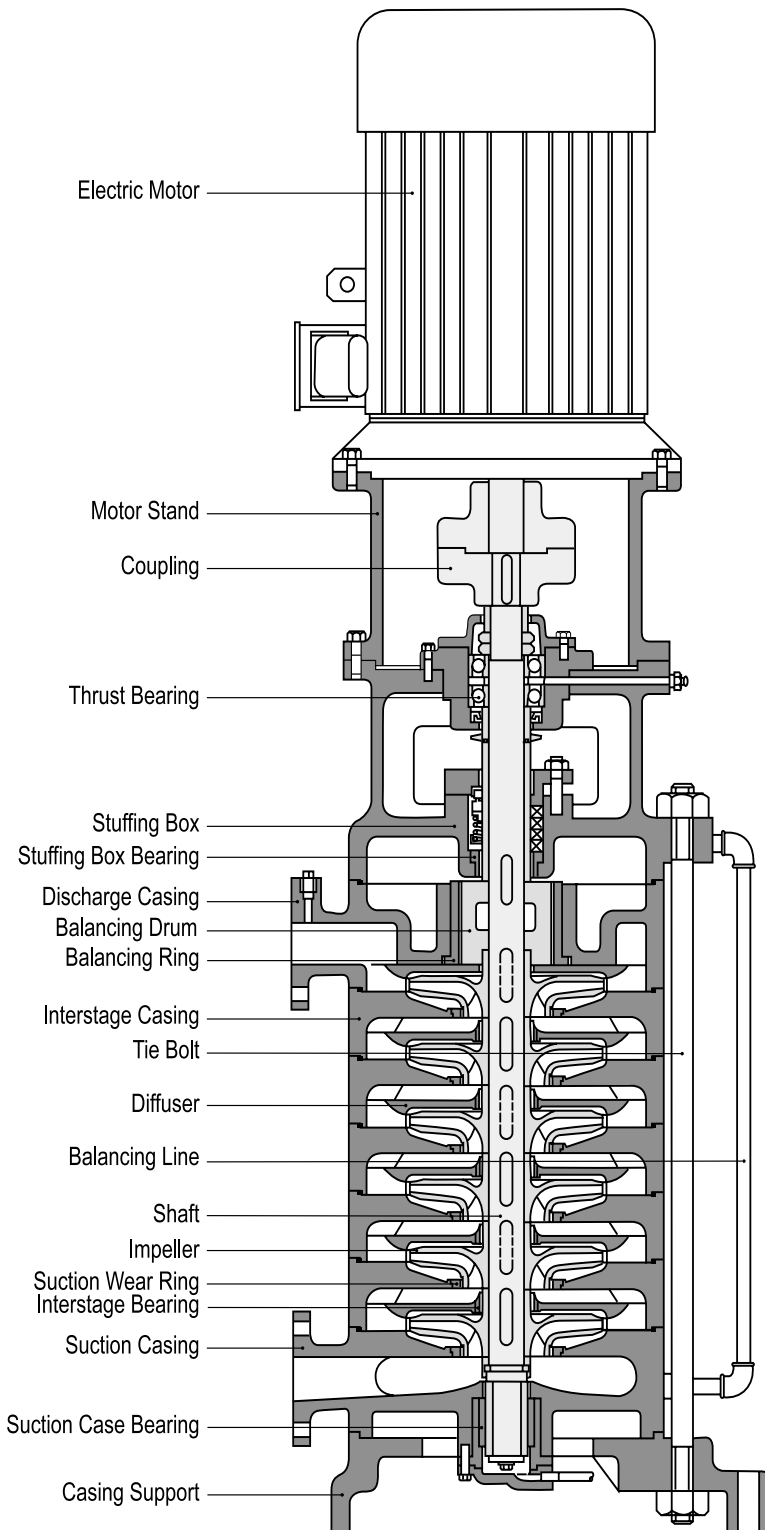

STANDARD FITTED

PARTS	MATERIAL
Impeller	Din 1.4541
Shaft	SS416
Suction Casing	Cast Iron ASTM A-48
Interstage Casing	Cast Iron ASTM A-48
Discharge Casing	Cast Iron ASTM A-48
Diffuser	Cast Iron ASTM A-48
Suction Case Bearing	PTFE
Interstage Bearing	Alloy 938 ASTM-B271
Suction Wear Ring	Cast Iron ASTM A-48
Balancing Drum	Cast Iron ASTM A-48
Balancing Ring	Cast Iron ASTM A-48
Tie Bolt	ASTM 1045
Balancing Line	Galvanized Steel
Stuffing Box	Cast Iron ASTM A-48
Casing Support	Cast Iron ASTM A-48

316 SS FITTED

PARTS	MATERIAL
Impeller	SS316
Shaft	SS316 or Duplex
Suction Casing	Cast Iron ASTM A-48
Interstage Casing	Cast Iron ASTM A-48
Discharge Casing	Cast Iron ASTM A-48
Diffuser	Cast Iron ASTM A-48
Suction Case Bearing	PTFE
Interstage Bearing	Alloy 938 ASTM-B271
Suction Wear Ring	Cast Iron ASTM A-48
Balancing Drum	SS316
Balancing Ring	Cast Iron ASTM A-48
Tie Bolt	ASTM 1045
Balancing Line	Din 1.4541
Stuffing Box	Cast Iron ASTM A-48
Casing Support	Cast Iron ASTM A-48

ALL 316 SS FITTED

PARTS	MATERIAL
Impeller	SS316
Shaft	Duplex 2205
Suction Casing	SS316
Interstage Casing	SS316
Discharge Casing	SS316
Diffuser	SS316
Suction Case Bearing	PTFE
Interstage Bearing	PTFE
Suction Wear Ring	SS316
Balancing Drum	316 Stellite Coated
Balancing Ring	SS316
Tie Bolt	ASTM 1045
Balancing Line	SS316
Stuffing Box	SS316
Casing Support	Cast Iron ASTM A-48

Coverage Charts

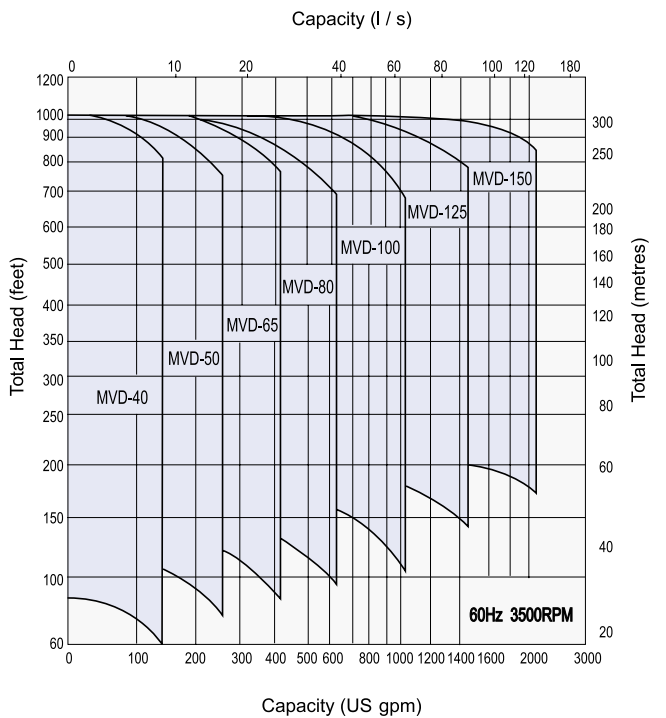
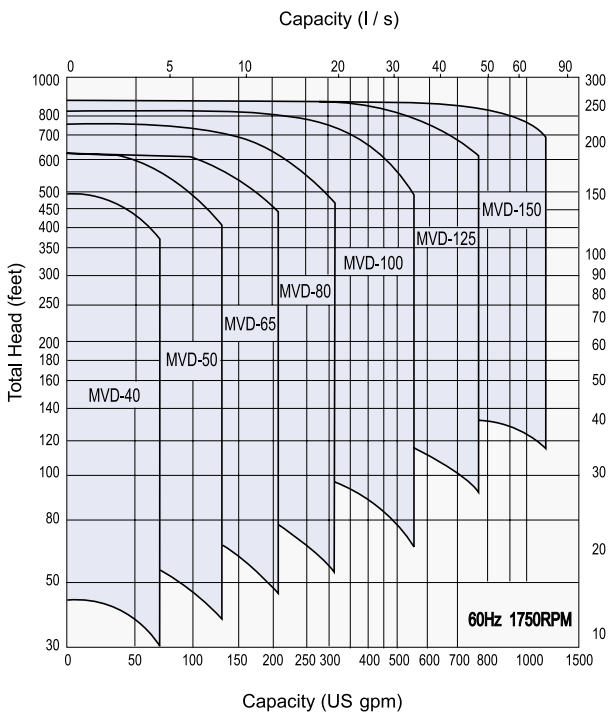
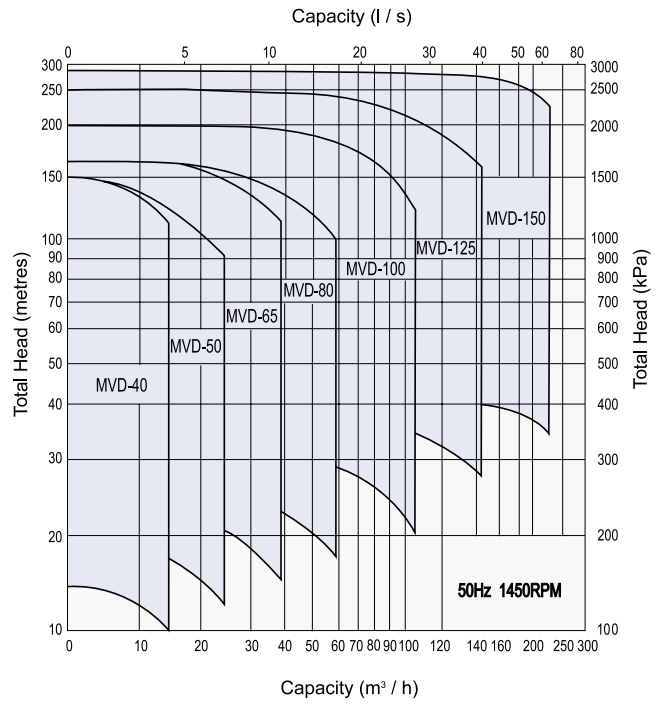
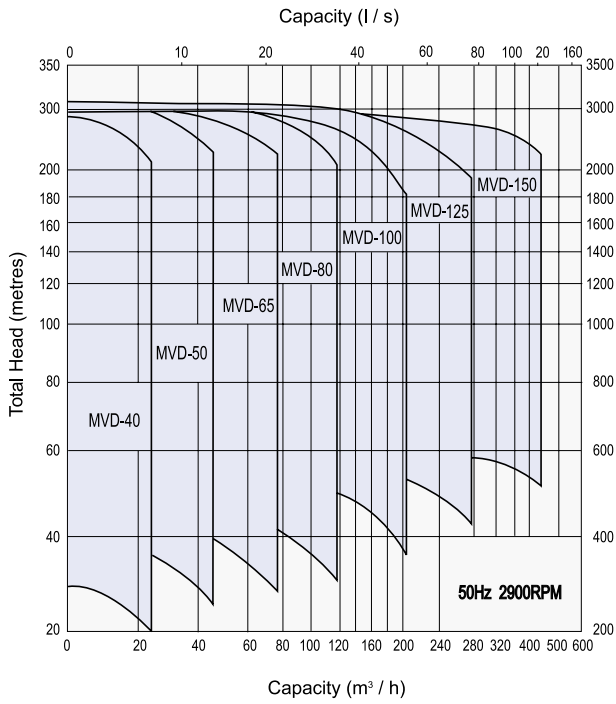

We reserve the right to amend designs without notice.