

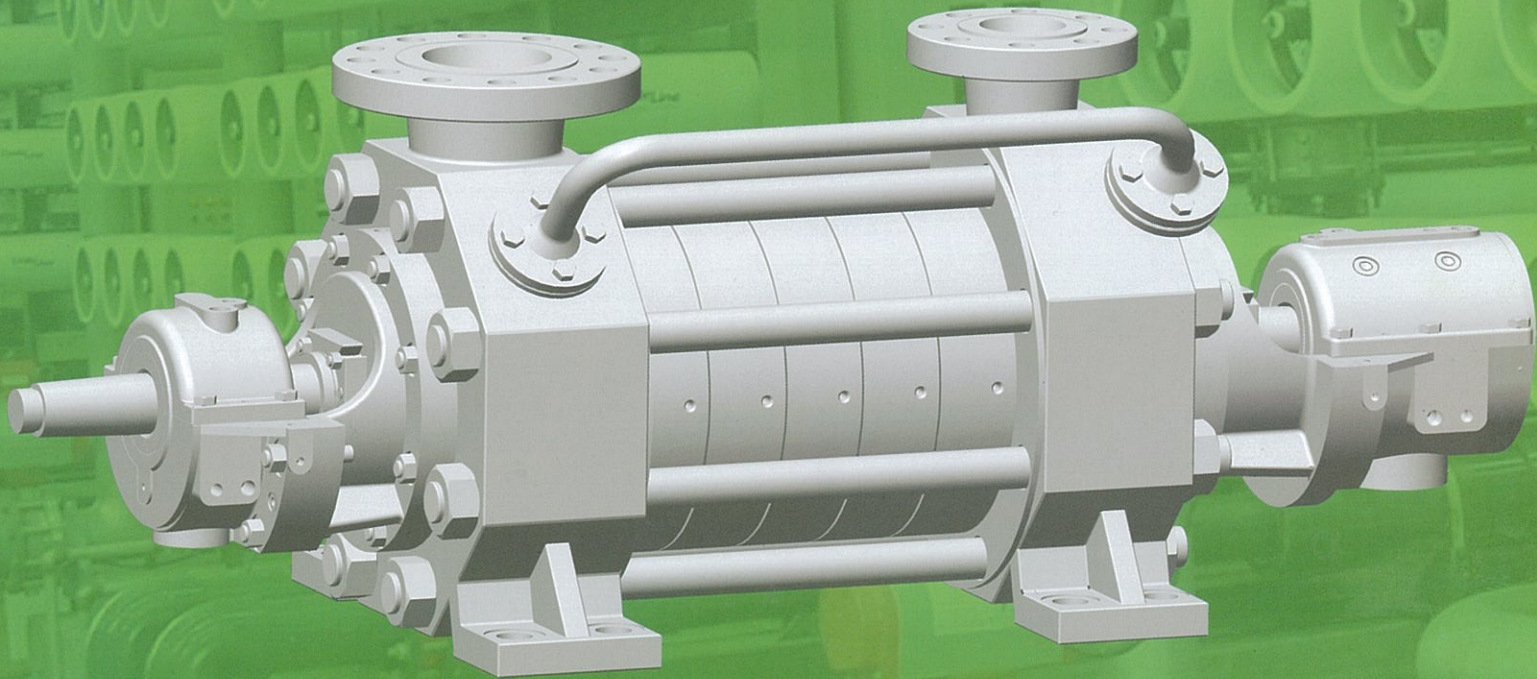

Acme pumps

HP High Pressure Pump



Engineered For Quality, Dedicated To Service

Acme Pumps is a leading manufacturer of high quality pumps originating from U.S.A. We provide our customers worldwide with high-efficiency pumps of superior quality that are reliable yet cost-efficient.

With ISO 9001-2000 certified manufacturing facilities in China and Singapore, we invest in leading technology, R & D, manufacturing processes and a state-of-the-art testing facility. We use only the highest quality precision and sand castings from selected foundries with specialized steel and pump components imported from Europe & America.

We design and manufacture pumps and pumping systems fully compliant with recognized international standards and approved by local and international authorities such as CCS, PSB and FM for a variety of markets and applications.

To maintain our leading position, we are committed to client-oriented research and development. Our R & D team applies the latest technology available in the pump industry to constantly innovate our product designs.

ACME HP centrifugal pumps are horizontal multi-stage ring-section pump specifically designed for the RO application.

They are engineered and built to ensure a reliable and safe performance while providing continuous service life at an efficient cost. The **HP** range of pumps has the most comprehensive hydraulic coverage and variety of materials available in the industry.

Features

More than 3mm corrosion allowance for extended use in corrosive applications.

Efficient balancing drum design results in both seals under suction pressure and low residual axial load on the thrust bearing.

Seal housing is constructed to accommodate a wide range of seal designs and configurations to meet severe heavy-duty requirements.

Heavy-duty, stiff solid shaft design ensures critical speed above the operating speed and less than 0.05 mm shaft deflection at the seal face in all operating conditions. These extend pump and seal life.

Precision cast and dynamic balanced impellers reduce vibration and ensure smooth operations over a wide range of duties.

Heavy-duty bearing housing and sleeve bearings are standard on all Acme HP pumps ensure long life and reliability.

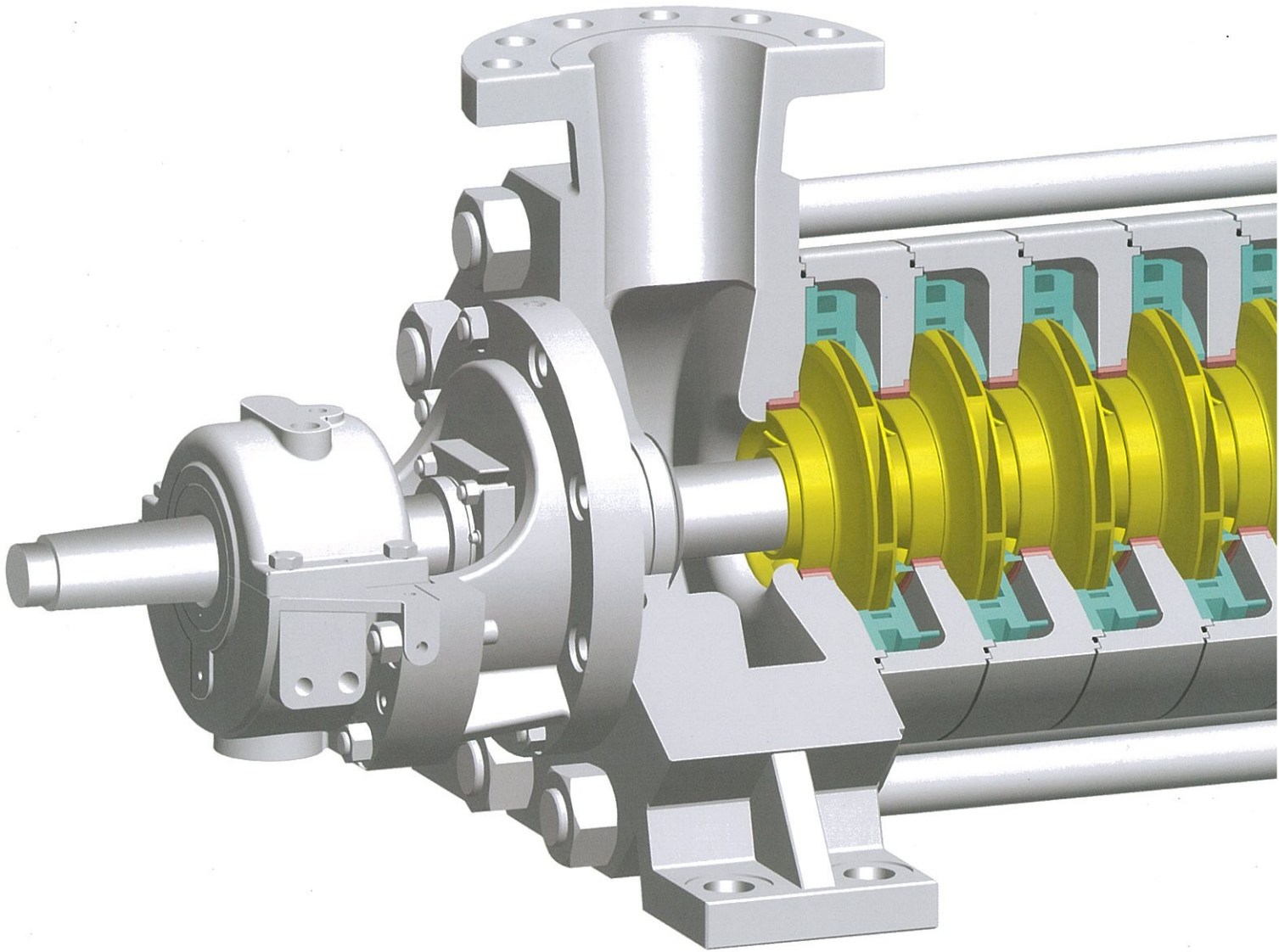

Precision cast and dynamic balanced impellers reduce vibration and ensure smooth operations over a wide range of duties

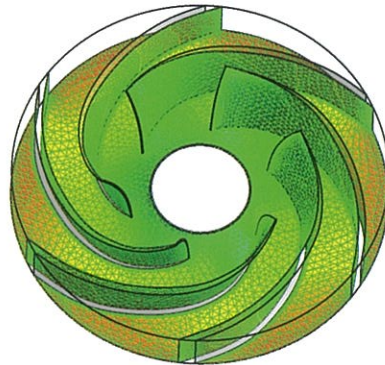

CFD designed impellers and diffusers to optimize the hydraulic performance.

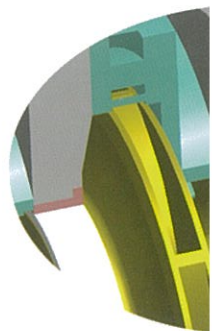

High-performance rings and balanced efficiency

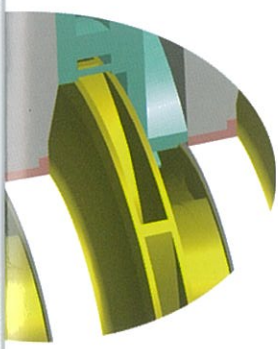
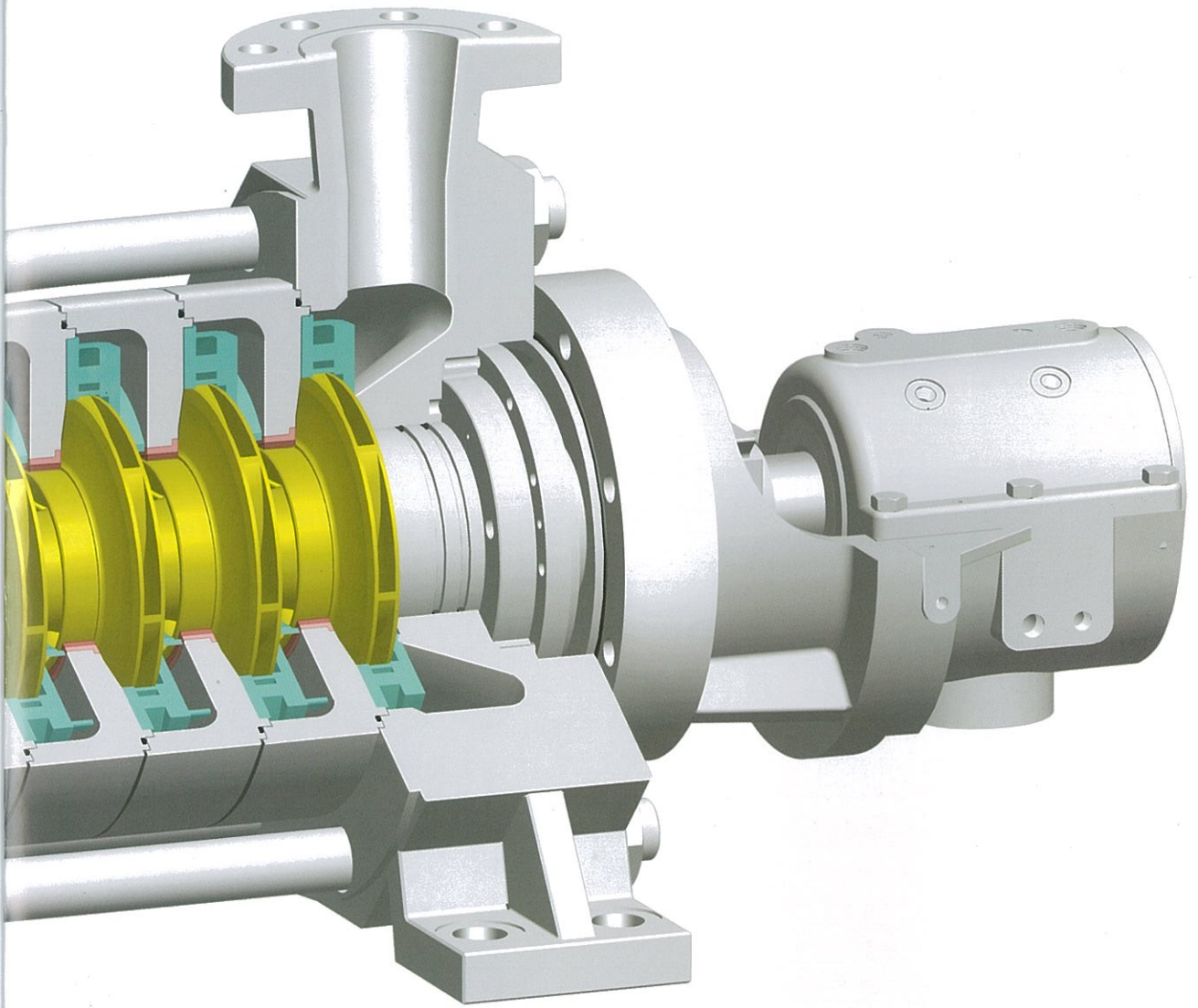

ce material for wear
ing device increases
nd reduce downtime.

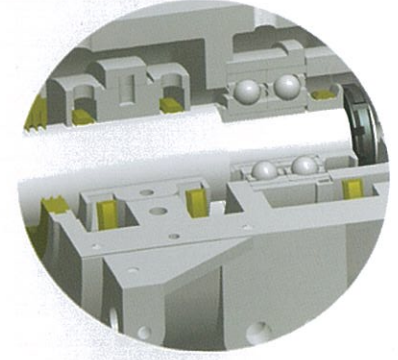
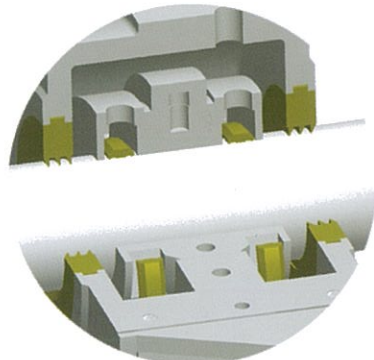

Heavy-duty sleeve bearings ensure long life and reliability.

Coverage charts

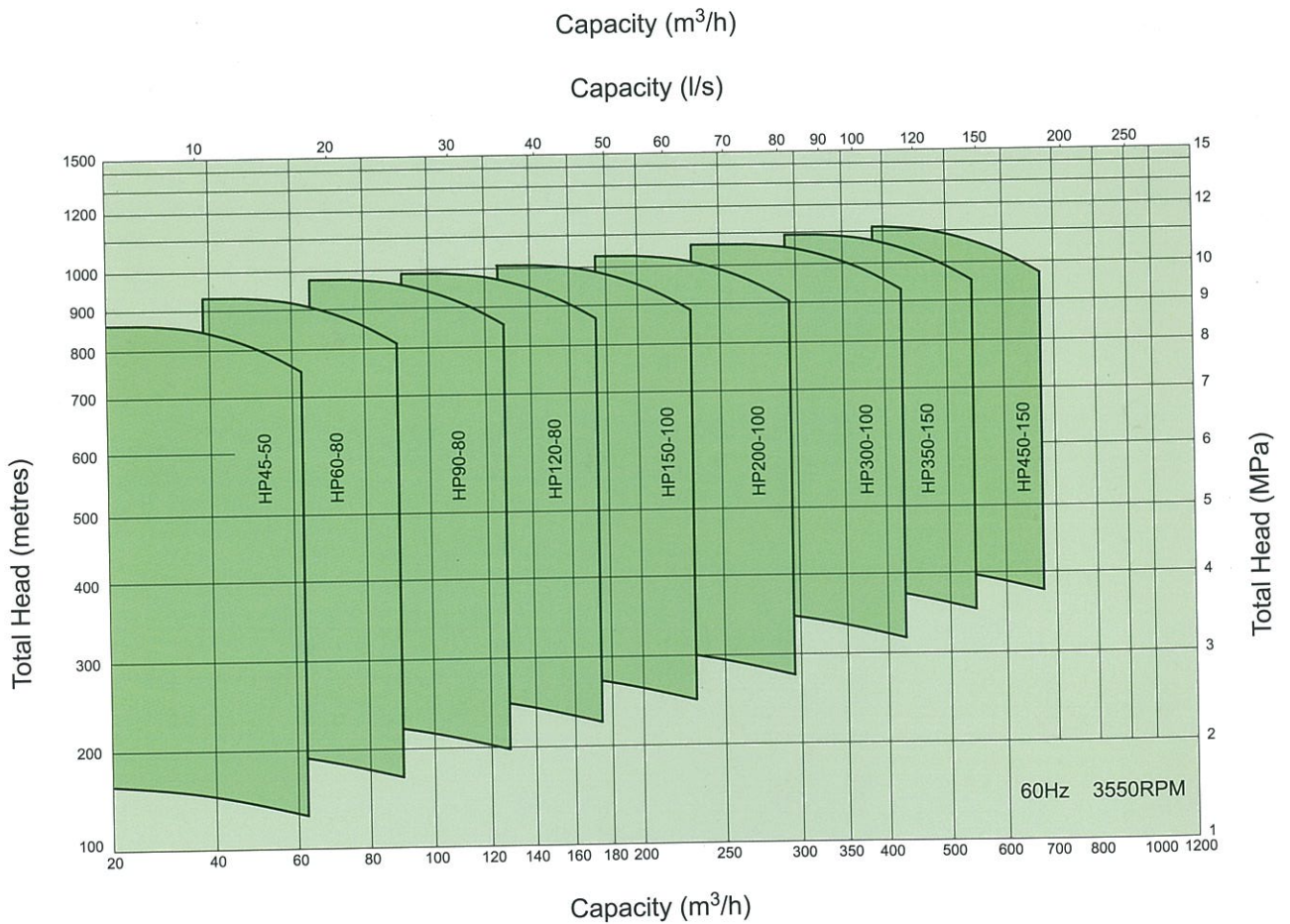
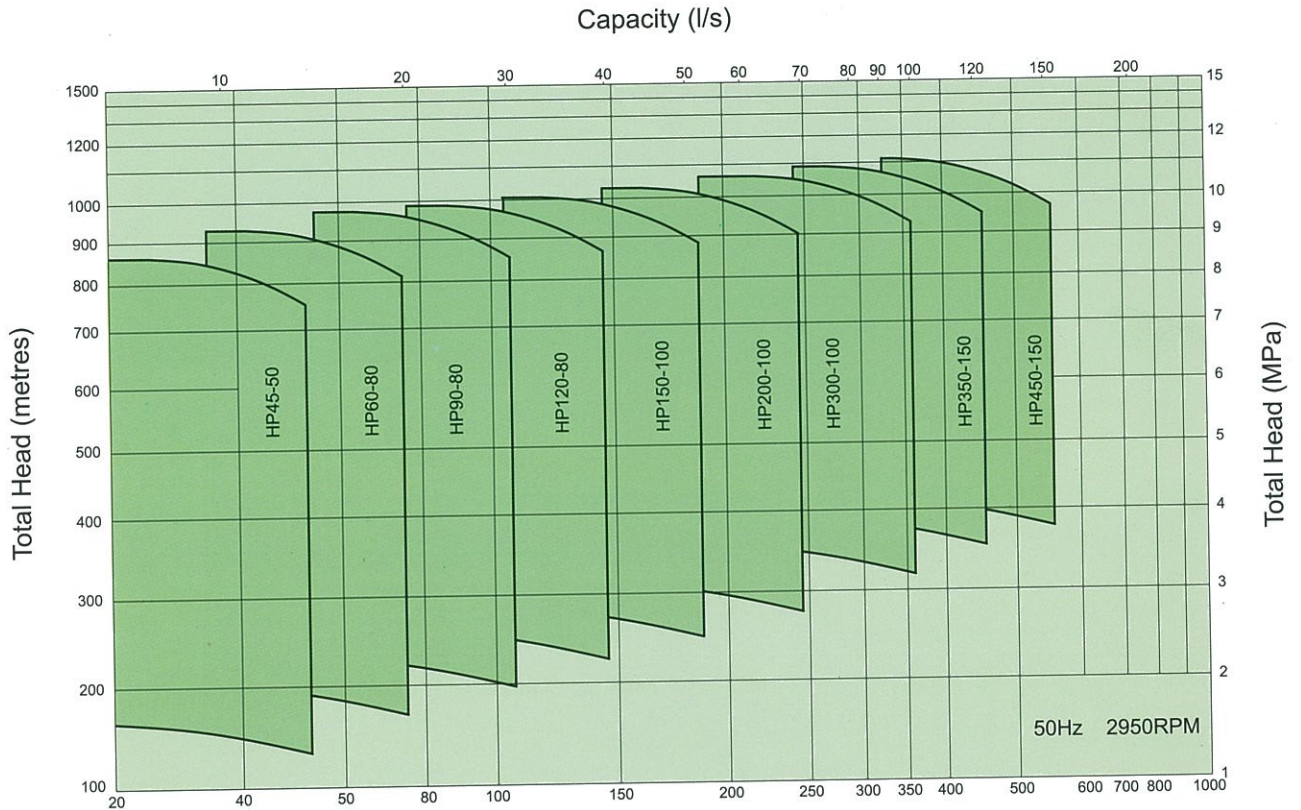



SINGAPORE

48A Changi South Street 1

Singapore 486114

Tel: 65 6545 7735, Fax: 65 6545 3411

Email: acme_sin@acmepump.com

CHINA

Block 30 Wuxi National High-Tech Industrial Park

Wuxi, Jiangsu, 214028, P.R.China

无锡国家高新技术产业开发区30号地块

Tel: 86 510 8522 9403, Fax: 86 510 8522 9401

Email: acme_wuxi@acmepump.com